

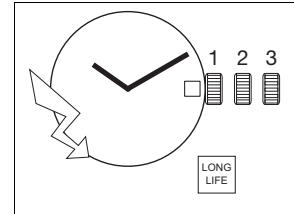

10 1/2" ETA E63.041

CT E63041 ESI 535323 02 11.08.2014

10 1/2" Ø 23,30 mm



Movement height	Altura sobre máquina	Altezza sopra movimento	1,95 mm
Height on battery	Altura sobre pila	Altezza sopra pila	No 373: 2,10 mm No 371: 2,50 mm
Number of jewels	Número de piedras	Numero di pietre	8
Frequency	Frecuencia	Frequenza	32'768 Hz

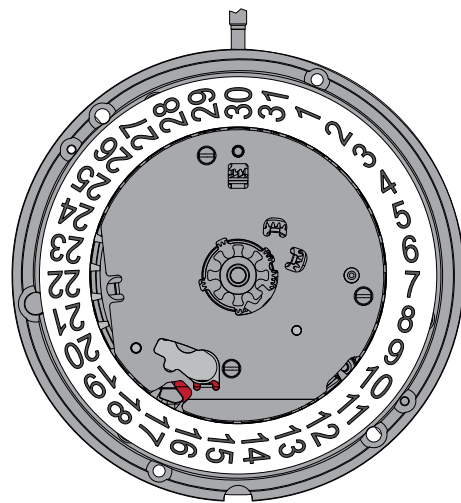
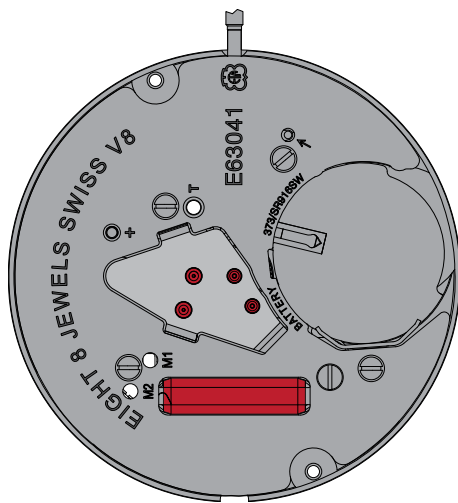

The repair and reconditioning work must only be performed by properly trained personnel.
Las tareas de reparación y revisión sólo deben ser llevadas a cabo por personal debidamente formado.
I lavori di riparazione e di revisione devono essere eseguiti esclusivamente da personale adeguatamente formato.



General information



Before starting work, please study this "Technical communication" carefully.



Eye protection is obligatory for all operations / work on the movement!



ETA SA disclaims any liability in case of damage arising from failure to observe this "Technical communication".

Environmental protection requirements



The legal provisions relating to waste handling and disposal must be observed in all operations / work on the movement!

In particular, lubricating and cleaning products harmful to the environment must be disposed of in accordance with the rules!



Substances prone to cause water pollution must be stored, transported, collected and disposed of in appropriate vessels.

Under no circumstances must they pollute the soil or be poured into sewage systems!

Explanation of symbols



Caution! Risk of material damage!

Below are some obligatory instructions for preventing any material damage!



Below is some advice for use and important information.

Información general



Esta "Comunicación técnica" deberá estudiarse muy bien **antes** de comenzar los trabajos.



Es obligatorio utilizar protección ocular para todos los trabajos en y con el reloj.



ETA SA no se hace responsable de los daños provocados como consecuencia de la inobservancia de esta "Comunicación técnica".

Normas de protección medioambiental



Deberá cumplirse la normativa legal relativa al reciclaje y la eliminación correctos de los residuos en todos los trabajos en y con el reloj.

En especial, deberán eliminarse correctamente los productos lubricantes y de limpieza peligrosos para el medio ambiente.



Las sustancias contaminantes del agua deben recogerse, almacenarse, transportarse y eliminarse en recipientes adecuados.

En ningún caso se permitirá que contaminen el suelo o que lleguen a la canalización.

Significado de los símbolos



Atención Peligro de daños materiales

Instrucciones que deberán respetarse necesariamente para evitar daños materiales.



Consejos de aplicación e información importantes.

Informazioni generali



Questa "Comunicazione Tecnica" deve essere studiata attentamente **prima** dell'inizio dei lavori.



Per tutti i lavori su e con il movimento dell'orologio è obbligatorio proteggere gli occhi!



ETA SA declina qualunque responsabilità per eventuali danni causati dalla mancata osservanza della presente "Comunicazione tecnica".

Disposizioni relative alla protezione ambientale



Per tutti i lavori su e con il movimento dell'orologio si dovranno rispettare le disposizioni di legge relative al corretto riciclaggio e smaltimento dei rifiuti!

In particolare si dovrà provvedere al corretto smaltimento di lubrificanti e detergenti nocivi per l'ambiente!



Le sostanze inquinanti per l'acqua devono essere conservate, trasportate, raccolte e smaltite in contenitori adatti.

Queste non devono inquinare il terreno o arrivare nelle canalizzazioni!

Spiegazione dei simboli



Attenzione! Pericolo di danni materiali!

Seguono importanti indicazioni che devono essere tassativamente rispettate per evitare danni materiali!



Seguono consigli per l'uso e informazioni importanti.

List of components - Lista de piezas - Lista fornitori

Pos	No	No CS	Article number Número de artículo Numero articolo	List of components	Lista de piezas	Lista fornitori
1	100	10.020.06	Var	Main plate, assembled	Platina, montada	Piastra, montata
2	407	31.121.00	7613226088788	Sliding pinion	Piñón corredizo	Pignone scorrevole
3	405	51.020.21	7613226085039	Handsetting stem	Tija de puesta en hora	Albero di messa all'ora
4	435	51.050.00	7613226088795	Yoke	Báscula de piñón corredizo	Bascula del pignone scorrevole
5	443/1	51.080.06	7613226088801	Setting lever, assembled	Tirete, montado	Tiretto, montato
6	445	51.090.00	7613226088818	Setting lever jumper	Muelle flexible de tirete	Scatto del tiretto
7	-	31.107.00	7613226088832	Time setting gear	Rueda de transmisión de puesta en hora	Rinvio di messa all'ora
8	4072	80.209.00	7613226088849	Distance piece for bridle -	Tirante de brida -	Spessore della brida -
9	4021	20.582.00	7613226088856	Stator	Estátor	Statore
10	4211	20.580.00	7613226088863	Rotor	Rotor	Rotore
11	203	30.012.00	-	Intermediate wheel	Rueda intermedia	Ruota intermedia
12	210	30.025.00	7613226088887	Third wheel	Rueda primera	Ruota mediana
13	227	30.027.00	-	Second wheel without seconde	Rueda de segundos sin segundo	Ruota dei secondi senza secondi
14	110	10.048.07	Var	Train wheel bridge, jewelled	Puente de rodaje, empedrado	Ponte del rotismo, con pietre
15	4060	20.290.06	7613226088467	Bobine, montée	Spule, montiert	Coil, assembled
16	4401	20.761.00	7613226088931	Bridle +	Brida +	Brida +
17	4046	20.651.00	7613226088948	Battery insulator	Aislador de pila	Isolatore della pila
18	4000	10.513.00	7613226088986	Electronic module	Módulo electrónico	Modulo elettronico
19	4038	20.584.00	Var	Electronic module cover	Cubre-módulo electrónico	Copri-modulo elettronico
20	242	31.083.00	Var	Cannon pinion with driving wheel	Cañón de minutos con arrastrador	Pignone calzante con conduttore
21	260	31.046.06	7613226086418	Minute wheel, assembled	Rueda de minutería, montada	Ruota della minuteria, montata
22	2557/1	91.440.22	Var	Date indicator	Indicador de fecha	Indicatore della data
23	255/1	31.046.06	Var	Hour wheel, assembled	Rueda de horas, montada	Ruota delle ore, montata
24	2556	33.020.00	Var	Date indicator driving wheel	Rueda de arrastre del indicador de fecha	Ruota conduttrice ell'indicatore della data
25	2566	53.200.00	7613226086449	Date corrector	Corrector de fecha	Correttore della data
26	2576	53.080.00	7613226086456	Date jumper	Muelle flexible de fecha	Scatta-data
27	2740	13.101.00	Var	Calendar mechanism maintaining plate	Placa de sujeción del mecanismo de calendario	Placca di guardia del meccanismo del calendario
28	2575	63.030.00	7613226086463	Date jumper spring	Resorte del muelle flexible de fecha	Molla dello scatta-data
29	4929	20.570.00	Var	Battery	Pila	Pila
30	4412	10.601.00	7613226018242	Battery limiting spring	Muelle de limitación de pila	Molla di limitazione della pila
900	-	88.502.00	-	Cylindrical head screw 1x - Pos. 8: Screw for distance piece for bridle- 1x - Pos. 14: Screw for train wheel bridge 1x - Pos. 16: Screw for bridle +	Tornillo de cabeza cilíndrica - Pos. 8: Tornillo de tirante de brida - - Pos. 14: Tornillo del puente de rodaje - Pos. 16: Tornillo de brida +	Vite a testa cilíndrica - Pos. 8: Vite del spessore della brida - - Pos. 14: Vite per ponte del rotismo - Pos. 16: Vite per brida +
901	-	88.542.00	-	Countersunk head screw 3x - Pos. 19: Screw for electronic module cover	Tornillo de cabeza cónica - Pos. 19: Tornillo del cubre-módulo electrónico	Vite a testa conica - Pos. 19: Vite del copri-modulo elettronico
902	-	88.582.00	-	Shouldered flat head screw 1x - Pos. 19: Screw for electronic module cover	Tornillo de asiento, cabeza chata - Pos. 19: Tornillo del cubre-módulo electrónico	Vite con piano di appoggio, testa piana - Pos. 19: Vite del copri-modulo elettronico
903	-	88.542.00	-	Countersunk head screw 3x - Pos. 27: Screw for calendar mechanism maintaining plate	Tornillo de cabeza cónica - Pos. 27: Tornillo de placa de sujeción del mecanismo de calendario	Vite a testa conica - Pos. 27: Vite placca di guardia del meccanismo del calendario
				Variant	Variante	Variante

**Interchangeability and variants
can be found on the
ETA ONLINE SHOP (EOS):**

www.eta.ch

- Support Center
- Support Center Portal

**La intercambiabilidad y las
variantes se encuentran en
ETA ONLINE SHOP (EOS):**

www.eta.ch

- Support Center
- Support Center Portal

**L'intercambiabilità e le varianti si
trovano sul
ETA ONLINE SHOP (EOS):**

www.eta.ch

- Support Center
- Support Center Portal

Materials - Fornituras - Forniture

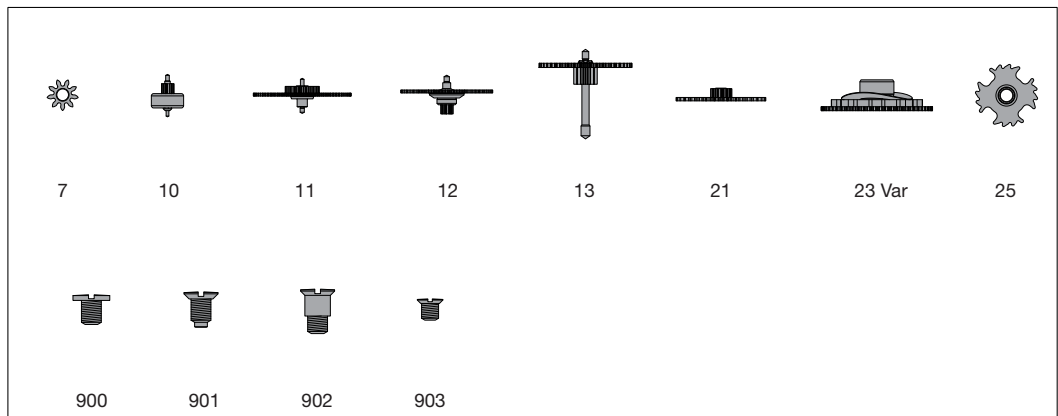
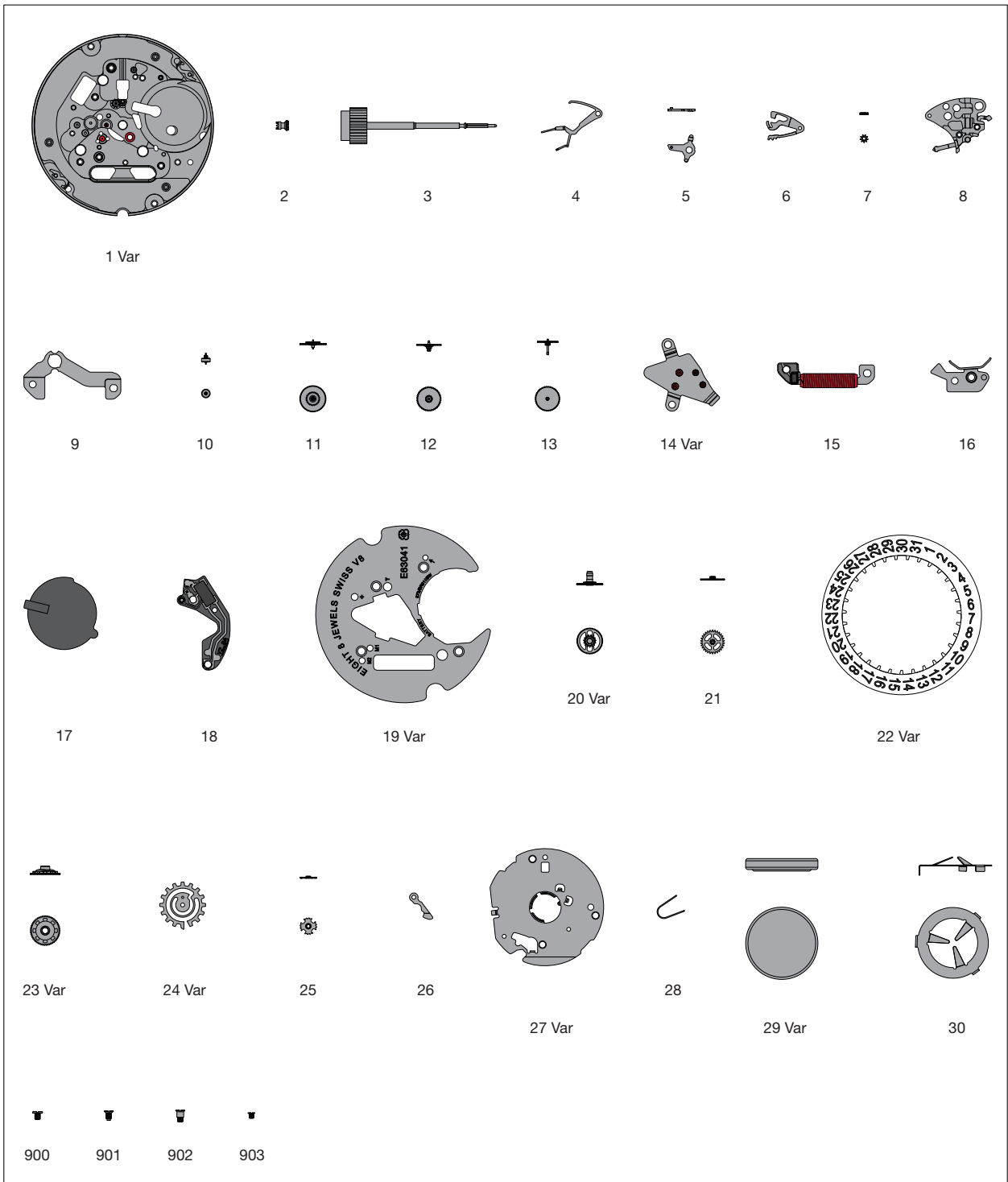

Order of assembly - Orden del montaje - Ordine dell'assemblaggio:
 Basic movement - Máquina de base - Movimento di base

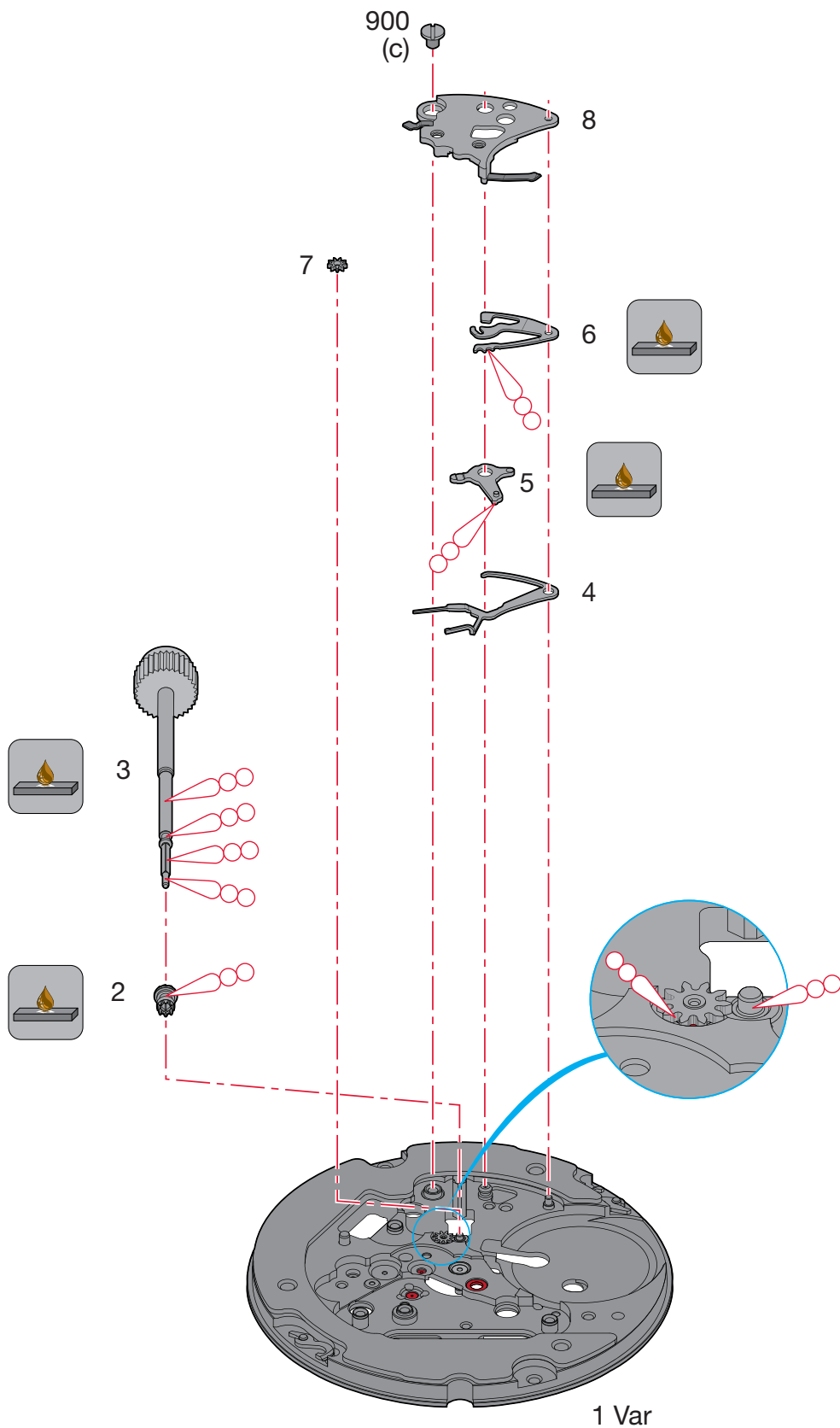

Assembling of the basic movement

(Parts listed in order of assembly)

Montaje de la máquina de base

(Lista de fornitureas por orden de ensamblado)

Montaggio del movimento di base

(Elenco delle forniture in ordine di montaggio)

1 Var	5	900 (1x)
2	6	
3	7	
4	8	

Lubrication - Lubricación - Lubrificazione

Thick oil or grease
 Aceite espeso o grasa
 Olio denso o grasso

**Moebius
 HP-1300**
 or / ó / o
Moebius D5



If the pieces to be assembled are not new, existing components must be treated with Moebius Fixodrop FK/BS 8941 before reassembly.

Si las piezas por ensamblar no son nuevas, los componentes existentes deben ser tratados con el Moebius Fixodrop FK/BS 8941.

Se non vengono montati dei nuovi pezzi, i componenti esistenti devono essere trattati prima del rimontaggio con Moebius Fixodrop FK/BS 8941.

Moebius Fixodrop FK/BS 8941

Volatile
 Flüchtig
 Volatile

Very volatile product!

To keep after usage in closed and airtight containers.

Producto muy volátil!

Para su uso posterior, mantener cerrados en recipientes herméticos.

Prodotto molto volatile!

Da conservare dopo l'uso in recipienti ermeticamente chiusi.

M_L Minimum torque for loosening**M_L Par mínimo para desatornillar****M_L Coppia minima per svitare**

(c) 0,8 Ncm

Order of assembly - Orden del montaje - Ordine dell'assemblaggio:
Wheel train - Rodaje - Ruotismo

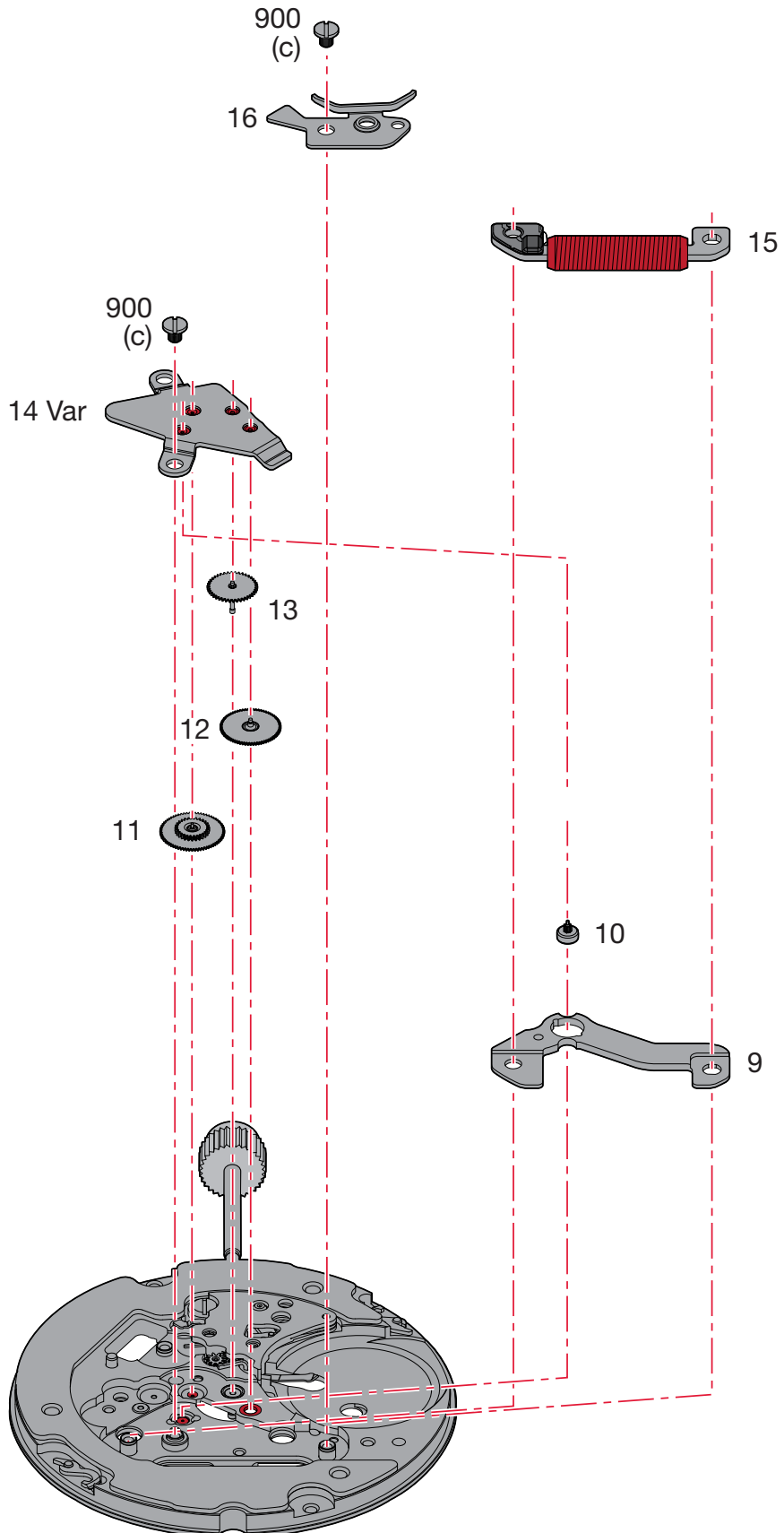

Assembling of the wheel train

(Parts listed in order of assembly)

Montaje del rodaje

(Lista de forniture por orden de ensamblado)

Montaggio del ruotismo

(Elenco delle forniture in ordine di montaggio)

9	13	16
10	14 Var	900 (1x)
11	900 (1x)	
12	15	

M_L Minimum torque for loosening**M_L Par mínimo para desatornillar****M_L Coppia minima per svitare**

(c) 0,8 Ncm

Order of assembly - Orden del montaje - Ordine dell'assemblaggio:
Electronic module - Módulo electrónico - Modulo elettronico

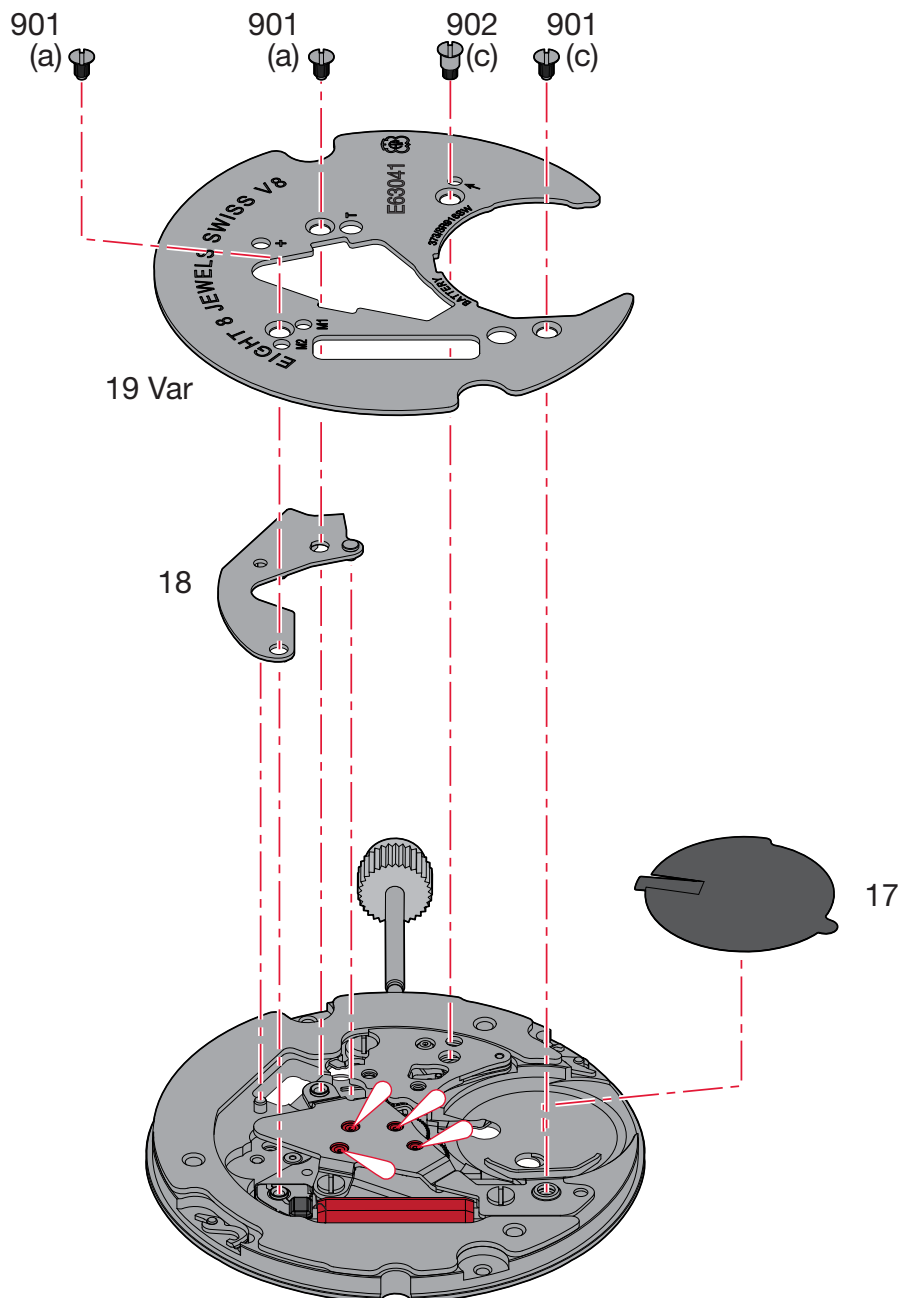

Assembling of the electronic module

(Parts listed in order of assembly)

Montaje del módulo electrónico

(Lista de fornitureas por orden de ensamblado)

Montaggio del modulo elettronico

(Elenco delle forniture in ordine di montaggio)

17	901 (3x)	
18	902 (1x)	
19 Var		

Lubrication - Lubricación - Lubrificazione

 Fine oil
Aceite fino **Moebius 9014**
Olio fluido

M_L Minimum torque for loosening**M_L Par mínimo para desatornillar****M_L Coppia minima per svitare**

- (a) 0,5 Ncm
- (c) 0,8 Ncm

Order of assembly - Orden del montaje - Ordine dell'assemblaggio:
 Handsetting mechanism and the calendar mechanism - Mecanismo de puesta en hora y de calendario -
 Meccanismo della messa all'ora e del calendario

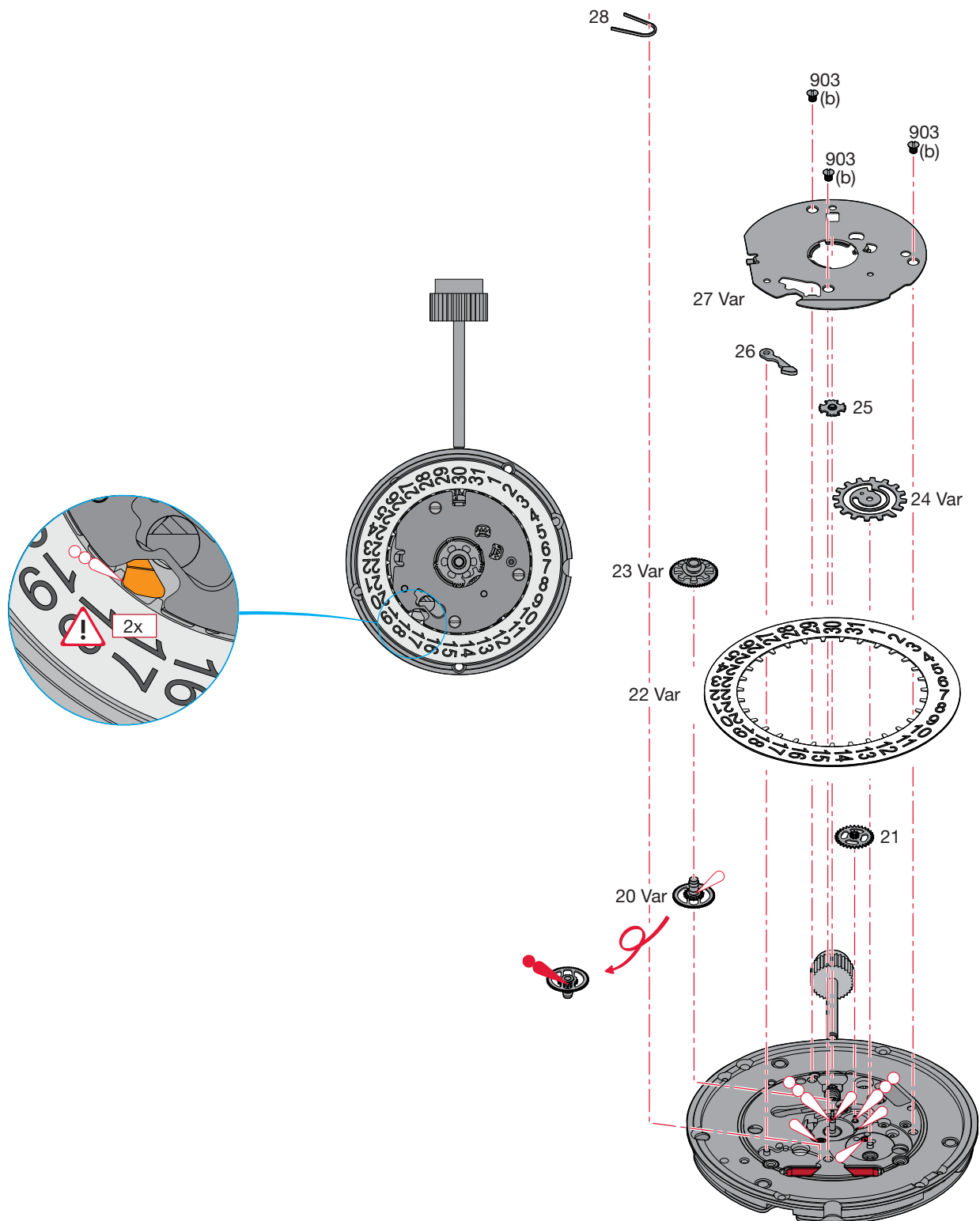

Assembling of the handsetting and the calendar mechanism

(Parts listed in order of assembly)

Montaje del mecanismo de puesta en hora y del mecanismo de calendario

(Lista de fornitureas por orden de ensamblado)

Montaggio della messa all'ora e del meccanismo del calendario

(Elenco delle forniture in ordine di montaggio)

20 Var	24 Var	903 (3x)
21	25	28
22 Var	26	
23 Var	27 Var	

Lubrication - Lubricación - Lubrificazione

 Fine oil
Aceite fino **Moebius 9014**
Olio fluido

 Grease
Grasa **Moebius 9501**
Grasso

 Thick oil or grease
Aceite espeso o grasa **Moebius HP-1300**
Olio denso o grasso **or / ó / o Moebius D5**

	Lubricate part 26. 1. Lubrique la pieza 26. Lubrificare il pezzo 26.
	Rotate part 22 approx 10 teeth with rapide correction. 2. Gire la pieza 22 unos 10 dientes con la corrección rápida. Ruotare il pezzo 22 di circa 10 denti con la correzione rapida.
	Lubricate again part 26. 3. Lubrique de nuevo la pieza 26. Lubrificare di nuovo il pezzo 26.
	Rotate part 22 approx 10 teeth with rapide correction again. 4. Gire de nuevo la pieza 22 unos 10 dientes con la corrección rápida. Ruotare di nuovo il pezzo 22 di circa 10 denti con la correzione rapida.

M_L Minimum torque for loosening**M_L Par mínimo para desatornillar****M_L Coppia minima per svitare**

(b) 0,7 Ncm

Order of assembly - Orden del montaje - Ordine dell'assemblaggio:
Battery and battery limiting spring - Pila para el muelle limitación de pila - Pila per la molla di limitazione della pila

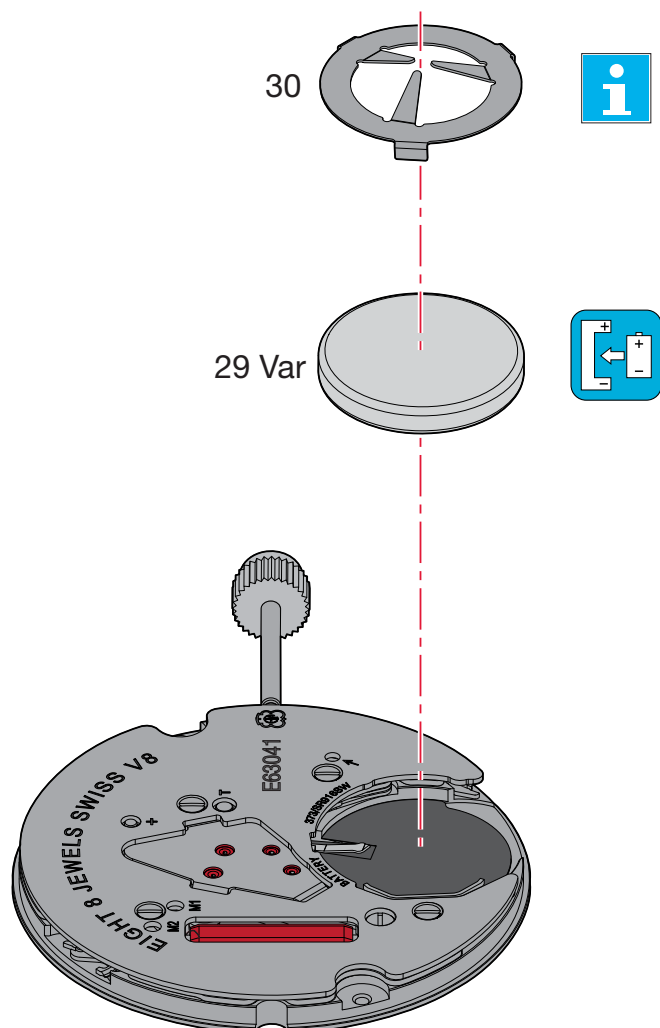

Assembling of the battery and the battery limiting spring

(Parts listed in order of assembly)

Montaje de la pila para el muelle de limitación de pila

(Lista de forniture por orden de ensamblado)

Montaggio pila per la molla di limitazione della pila

(Elenco delle forniture in ordine di montaggio)

29 Var

30

Pos 30:

The limit spring is only necessary when the distance from the battery to the base of the casing is too far.

For further details please go to:

Manufacturing Information

"FRAME FOR CASE"



El muelle de sujeción solo es necesario si la distancia entre la pila y el fondo de la caja es demasiado grande.

Para más información, véase:

Información del fabricante

"ARMAZÓN DE LA CAJA"

La molla distanziatrice è necessaria solo in caso di distanza ampia tra la batteria e il fondo della cassa.

Per dettagli, vedere:

Informazioni del produttore

"STRUTTURA PER CASSA"

Electrical tests - Controles eléctricos - Controlli elettrici

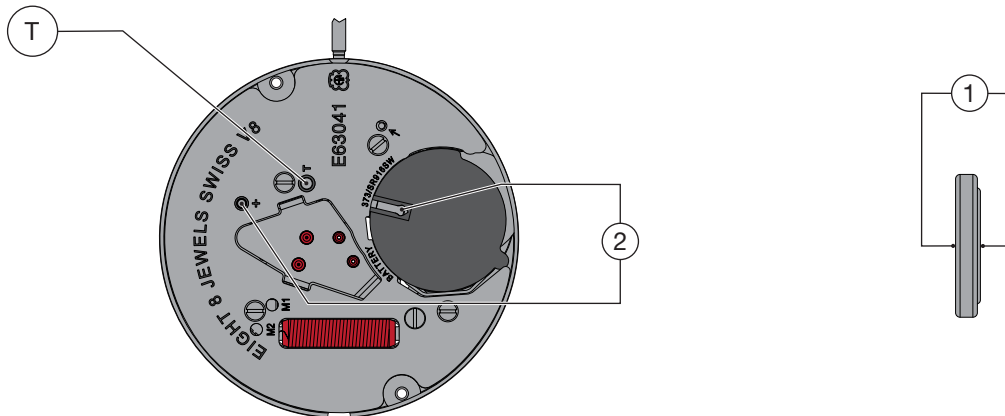

Position Posición Posizione	Setting of apparatus Escala de medición Scala di misura	Measurement Medición Misura	Test Control Controllo	Remarks Notas Osservazioni
1	2 V	1,55 V	Battery voltage Tensión de la pila Tensione de la pila	
2	2 V	The movement is fitted with a "Watchmodul C7". El movimiento está equipado con el módulo de reloj C7. Il meccanismo è dotato del modulo orologio C7.		
		Motor driven with 30 steps/min. Mando del con 30 pasos/min. Comando del motore con 30 pas- si/min.	Lower working-voltage limit. Limite inferior de la tensión de funcionamiento. Limite inferiore della tensione di fun- zionamento.	Measurement without battery, with variable external power supply, starting with 1.55 V, lower tension until movement stops. Medición sin pila, con alimentación exterior variable bajando de 1,55 V hasta la parada de la máquina. Misura senza pila con alimentazione esterna variabile, scendendo da 1,55 V fino all'arresto del movimento.
	10 µA	Consumption of movement Consumo de la máquina Consumo del movimento.	≤ 1,2 µA	Measurement without battery, with external power supply 1.55 V. Medición sin pila, con alimentación exterior de 1,55 V. Misura senza pila con alimentazione esterna di 1,55 V.
Function of stop lever, pos. 3 of handsetting stem. Funcionamiento del interruptor en pos. 3 de la tija de puesta en hora. Funcionamento dell'interruttore in posizione 3 dell'albero di messa all'ora.		≤ 0,5 µA	Measurement without battery, with external power supply 1.55 V. Medición sin pila, con alimentación exterior de 1,55 V. Misura senza pila con alimentazione esterna di 1,55 V.	

REMARQUES:

Accelerated mode:

For measurements and controls in accelerated mode, please contact ETA SA customer Services.

BEMERKUNGEN

Modo acelerado:

Para mediciones y controles en modo acelerado, póngase en contacto con el servicio de atención al cliente de ETA SA.

REMARKS

Modalità accelerata:

Per misurazioni e controlli in modalità accelerata, vi invitiamo a contattare il servizio clienti di ETA SA.

Checking the instantaneous rate

The Inhibition periode is
60 seconds.

Control de la marcha instantánea

Reglaje de la marcha por inhibición de
60 segundos.

Controllo della marcia istantanea

Regolazione della marcia per inibizione di
60 secondi.

Checking the instantaneous rate

The rate must be checked with an instrument that allows measuring over one or several periods of 60 seconds.

Check the rate at a temperature between 20° C and 25° C.

Current supply

Silver oxide battery
U = 1.55 V, "Low Drain" type.

Ø 9.50 mm, height 1.65 mm
Capacity 29 mAh (Renata).

Renata 373, Varta V373,
Energizer 373, SR 916 SW.

Ø 9.50 mm, height 2.05 mm
Capacity 40 mAh (Renata).

Renata 371, Varta V371,
Energizer 371, SR 920 SW.

Fitting the battery

Slide the battery against the contact strip
①. Press the battery firmly into its
mounting ②. The contact strip keeps the
battery in position.

The tweezers must not be electrically conductive!

Control de la marcha instantánea

El control de la marcha de la máquina debe hacerse obligatoriamente con la ayuda de un aparato para captar los impulsos del motor que permita una o un múltiplo integración de 60 segundos.

Verifique la medición en una temperatura 20° C y 25° C.

Alimentación

Pila al óxido de plata.
U = 1,55 V, tipo "Low Drain".

Ø 9,50 mm, Höhe 1,65 mm
Capacidad 29 mAh (Renata).

Renata 373, Varta V373,
Energizer 373, SR 916 SW.

Ø 9,50 mm, Höhe 2,05 mm
Capacidad 40 mAh (Renata).

Renata 371, Varta V371,
Energizer 371, SR 920 SW.

Colocación de la pila

Colocar la pila debajo de las dos lengüetas metálicas del cobre-módulo ①. Apretar la pila al fondo de su alojamiento ②. El dedo del cobre-módulo sujeta la pila en su sitio.

Las pinzas no deben ser conductoras de la electricidad!

Controllo della marcia istantanea

Il controllo della marcia del movimento si deve effettuare obbligatoriamente con un apparecchio che consenta di captare gli impulsi del motore con un'integrazione o un multiplo di 60 secondi.

Verificare il tasso ad una temperatura fra 20° C e 25° C.

Alimentazione

Pila all'ossido d'argento
U = 1,55 V, tipo "Low Drain" type.

Ø 9,50 mm, height 1,65 mm
Capacità 29 mAh (Renata).

Renata 373, Varta V373,
Energizer 373, SR 916 SW.

Ø 9,50 mm, height 2,05 mm
Capacità 40 mAh (Renata).

Renata 371, Varta V371,
Energizer 371, SR 920 SW.

Posa della pila

Far scivolare la pila sotto le due linguette metalliche del copri-módulo ①. Premere la pila al fondo del suo alloggiamento ②. Il dito del copri-módulo mantiene la pila nella sua posizione.

La pinzetta non deve condurre elettricità!

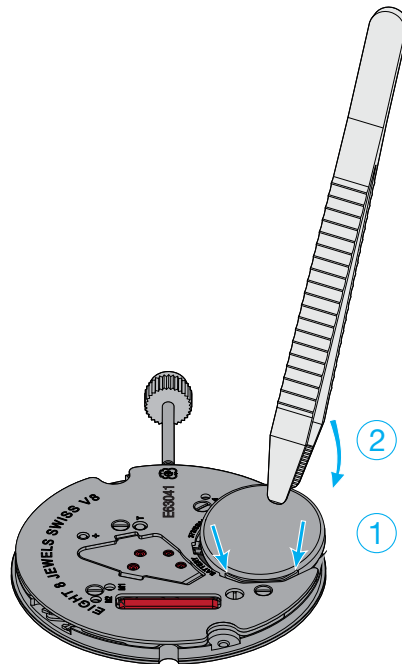

Removing the battery

Insert tweezers ① between module and battery (see drawing) and pry out the battery by gently lifting back ② the contact strip. Remove the battery ③ .

The tweezers must not be electrically conductive!

Retiro de la pila

Insertar unas pinzas ① entre el módulo y la pila (véase dibujo) y palanquear la pila apartando cuidadosamente el dedo del cubre-módulo ②. Sacar la pila ③ .

Las pinzas no deben ser conductoras de la electricidad!

Ritiro della pila

Far scivolare una pinzetta ① tra il modulo e la pila (vedi disegno) e fare leva sotto quest'ultima allargando leggermente il dito di sostegno verso dietro ②. Ritirare la pila ③ .

La pinzetta non deve condurre elettricità!

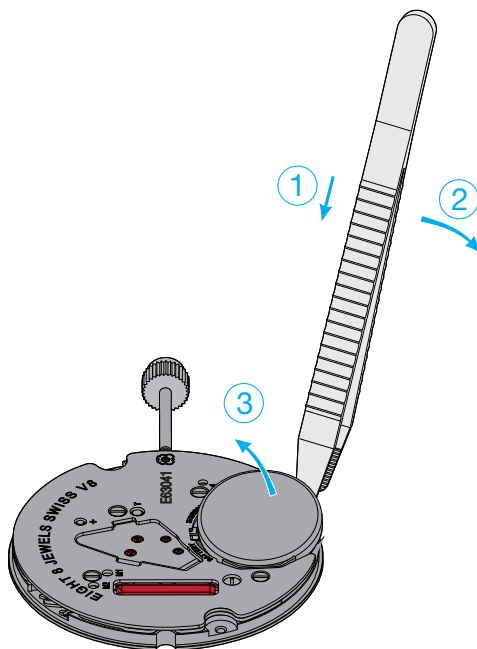

Extracting the stem

The handsetting stem must be pushed back to position 1 (neutral) before pressing on the point lying on the right sider of the setting lever.

Extracción de la tija de puesta en hora

Antes de pulsar el punto a la derecha del tirete, es obligatorio empujar la tija de puesta en hora en posición 1 (neutral).

Estrazione dell'albero di messa all'ora

Prima di premere il punto a destra del tiretto, è obbligatorio premere l'albero di messa all'ora in posizione 1 (neutra).

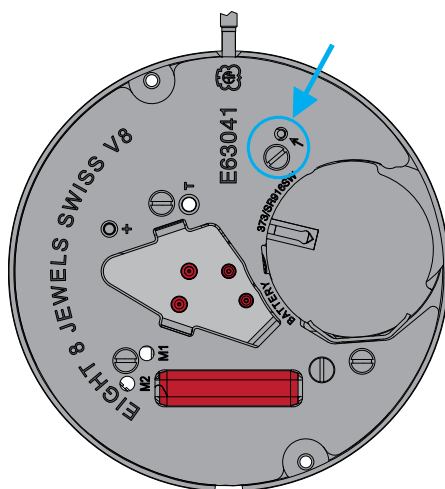

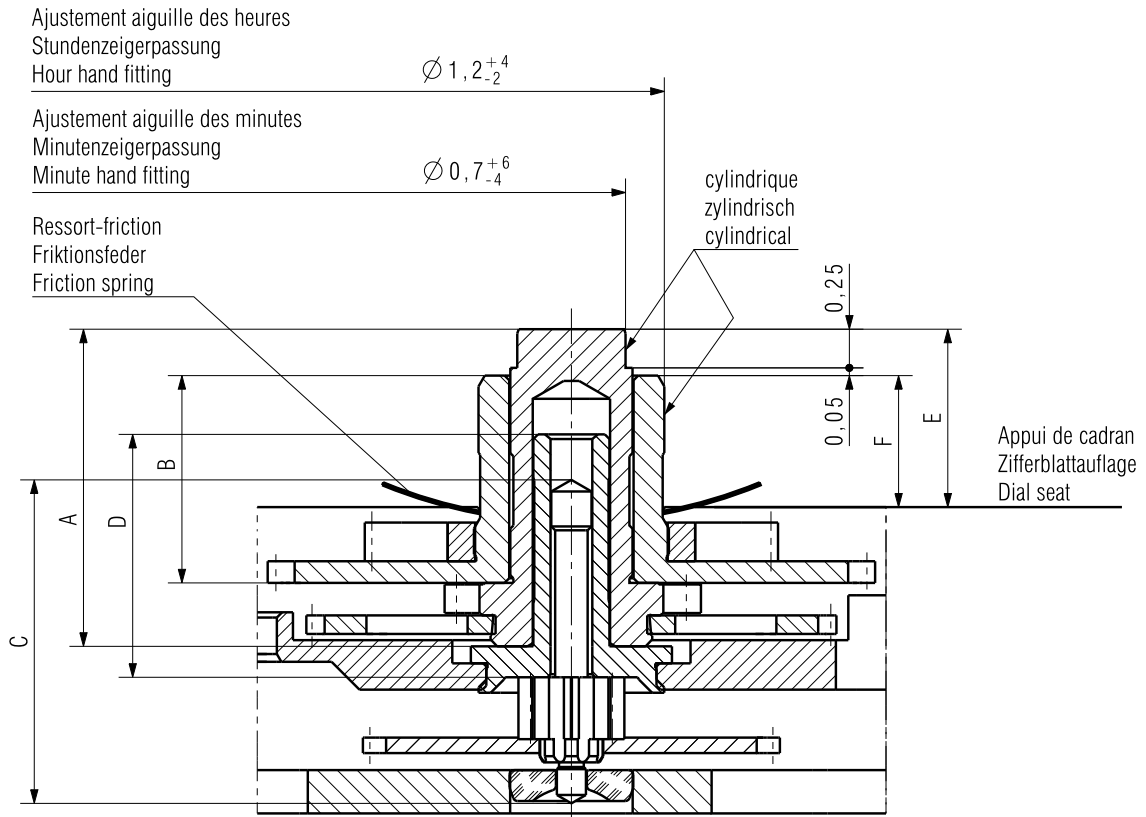

1) NIHS 91-30: 500g / 0,7 ms

2) NIHS 91-20: 500g / 2,0 ms

Aiguillage Zeigerwerkhöhe Hand fitting height	Longueur/Länge/Length				Dépassement Höhe über Zifferblattauflage Height over dial seat		Ep.cadran Zifferblattstärke Dial thickness
	A	B	C	D	E	F	
	Chaussée Minutenrohr Cannon-pinion	Roue des heures Stundenrad Hour wheel	Pignon des sec. au centre Zentrum- sekundentrieb Central sec. wheel pin.	Tube de centre Zentrumrohr Centre tube	Chaussée Minutenrohr Cannon-pinion	Roue des heures Stundenrad Hour wheel	
réduit niedrig reduced normal	1,80	1,09	2,091	1,57	0,9	0,6	0,3
1	2,05	1,34	2,091	1,57	1,15	0,85	0,4
2	2,30	1,59	2,091	2,07	1,4	1,1	
3	2,55	1,84	2,091	2,07	1,65	1,35	

Aiguilles Zeiger Hands	Aiguille des heures Stundenzeiger Hour hand		Aiguille des minutes Minutenzeiger Minute hand	
Masse/Masse/Mass	max.	mg	20	
Balourd/Unwucht/Unbalance	max.	µNm	1) 2) 1	
Force de chassage/Setzkraft/Press-in force	max.	N	30	
Inertie/Trägheit/Inertia	max.	gmm ²	0,3	

Caliber / Calibre / Caliber E6X.031/041	Masstab Echelle Scale --		CATIA V5
		Masse in mm Dimensions en mm Dimensions in mm	Tol.1/1000 mm

AIGUILLAGES ZEIGERWERKHÖHEN HAND FITTING HEIGHTS	Version 03	Revision Révision 00	Blatt Feuille Sheet 01/01
---	----------------------	-----------------------------------	---

ETA SA MANUFACTURE HORLOGÈRE SUISSE DEPUIS 1793 A COMPANY OF THE SWATCH GROUP	Ersatz für/En remplacement de/Remplacement for	Klass. Class. ZVACC	KUN
	Aenderung/Modification 30464	Ursprung Erzeugung Création Originale Creation Original 07.04.2009 SAC	Version Erzeugung Création Version Creation Version 24.06.2014 ZWJ

We reserve all rights for this document. It is meant for the recipient only and it may not be copied, printed or given to a third person without our written permission. Quedan reservados todos los derechos relacionados con este documento, que está dirigido únicamente al destinatario. Queda por lo tanto prohibida su copia, impresión a terceros sin nuestra autorización por escrito. Ogni diritto su questo documento è riservato. Il documento è indirizzato esclusivamente al destinatario e non può essere copiato, stampato o ceduto a terzi senza un'autorizzazione scritta.

Modifications compared with previous document versions**Modificaciones comparadas con las versiones anteriores del documento****Modifiche comparate con le versioni precedenti del documento**

Version Versión Version	Date Fecha Data	Modification	Modificación	Modifica	Page Página Pagina
02	11.08.2014	New drawing	Nuevo plan	Nuovo disegno	19
01	12.04.2013	New drawing	Nuevo plan	Nuovo disegno	19
00	18.06.2012	Basic version	Versión de base	Versione di base	--

All modifications reserved.

Salvo modificación.

Con riserva di ogni eventuale modifica.

This document can be found on the Support Center Portal (SCP):**www.eta.ch**

- Support Center
- Support Center Portal
- Technical Documents

Este documento se encuentran en el Support Center Portal (SCP):**www.eta.ch**

- Support Center
- Support Center Portal
- Technical Documents

Il presente documento si trovano sul Support Center Portal (SCP):**www.eta.ch**

- Support Center
- Support Center Portal
- Technical Documents



ETA^{SA}
MANUFACTURE HORLOGÈRE SUISSE
DEPUIS 1793

SC PRODUCT COMMUNICATION

Bahnhofstrasse 9
2540 Grenchen
Switzerland

Phone +41 (0)32 655 71 11
Fax +41 (0)32 655 71 74

contact@eta.ch
www.eta.ch